



Spicer® Driveshaft

Roadranger® More time on the road™

Application Guidelines

DSAG0200

September 2007

Driveline Sizing

Specifying a Spicer Driveline..... 2
 Driveline Specification Criteria 2
 Application Definitions 2
 Calculating Maximum Low Gear Torque 3
 Calculating Maximum Driveshaft Torque 5
 Application Guidelines 6
 10-Series Graph..... 6
 SPL Graph 7

Critical Speed

Critical Speed 8
 Standard Equation 8
 Simplified Equations 8
 Adjusted Critical Speed 9
 Maximum Driveshaft Length 9

Center Bearing Mounting

Center Bearing Mounting 10

Driveline Analysis

Driveline Analysis 11
 Design Criteria 11
 Torsional and Inertial Excitation 11
 Center Bearing Loading 15

Appendix

Application Form 17
 Spicer Standard Tube Sizes 19
 Joint Life vs. Joint Angles 20
 Charts 21
 Joint Kit Attaching Hardware and Torque Specs 26

Specifying a Spicer Driveline

Driveline Specification Criteria

Prime Factors:

- Net torque input
- Baseline duty cycle
 - On-highway tractor - 80,000 lbs. GCW
- Modifiers (+/- factors)
 - Duty cycle (vocation)
 - Gross Vehicle Weight (GVW/GCW)
 - Rear axle ratio
 - Universal joint working angle

Application Definitions

- Domestic applications - restricted to the continental United States and Canada.
 - On-highway - operation on well-maintained, concrete and asphalt roadways including turnpikes, interstates, and state routes with not more than 10% off-highway operation.
 - Off-highway - operation on unimproved dirt or gravel roads, as well as, poorly maintained paved roads, more than 10% of the time.
 - Line haul - operation on well maintained concrete and asphalt roadways including turnpikes, interstates, and state routes 100% of the time.
- Export applications - outside of the continental United States and Canada.

Driveline sizing for export applications is based on Maximum Driveshaft Torque **only** (see “Calculating Maximum Driveshaft Torque (Export Applications)” on page 5).

Calculating Maximum Low Gear Torque

Step 1 - Low Gear Torque Calculation

$$\text{LGT} = T \times \text{TLGR} \times \text{TE} \times \text{SR} \times \text{TCR} \times C$$

LGT = Maximum Driveshaft Low Gear Torque

T = Net Engine Torque or 95% of the Gross Engine Torque

TLGR = Transmission Low Gear Ratio (forward)*

TE = Transmission Efficiency (automatic = 0.8; manual = 0.85)

SR = Torque Converter Stall Ratio (if applicable)

TCR = Transfer Case Ratio (if applicable)

C = Transfer Case Efficiency (if applicable, 0.95)

* Some applications require deep reduction transmissions for speed-controlled operations such as paving and pouring. In these applications it may be more appropriate to use the second lowest forward transmission ratio to calculate the Maximum Low Gear Torque. To use the second lowest forward gear ratio to calculate LGT, **all three** of the following conditions must be met:

1. Lowest forward gear ratio numerically greater than 16:1.
2. Split between the lowest forward gear ratio and the second lowest forward gear ratio is greater than 50%.
3. Startability Index must be greater than 25 (see below calculation).

Startability Index Calculation

$$\text{SI} = (T \times \text{TR} \times \text{AR} \times \text{TCR} \times 942.4) / (\text{RR} \times \text{GCW})$$

SI = Startability Index

T = Engine Clutch Engagement Torque at 800 RPM

TR = Transmission Second Lowest Forward Gear Ratio

AR = Axle Ratio

TCR = Transfer Case Ratio (if applicable)

RR = Tire Rolling Radius (in)

GCW = Maximum Gross Combination Weight (lbs)

Step 2 - Wheel Slip Calculation

$$\text{WST} = (.71 \times W \times \text{RR}) / (11.4 \times \text{AR})$$

WST = Wheel Slip Torque Applied to the Driveshaft

W = Axle Capacity (lbs)

RR = Tire Rolling Radius (in)

AR = Axle Ratio

Step 3 - Gradeability Calculation

Calculate the torque required for 25% gradeability.

Note: For Linehaul applications with 3.10 axle ratio or numerically larger only.

$$GT = (.265 \times RR \times GVW) / (11.4 \times AR)$$

GT = Net Driveline Torque at 25% Gradeability

RR = Tire Rolling Radius (in)

GVW = Gross Vehicle Weight (lbs)

AR = Axle Ratio

Step 4 - Overall Low Gear Ratio Calculation

$$OLGR = TLGR \times SR \times TCR$$

OLGR = Overall Low Gear Ratio

TLGR = Transmission Low Gear Ratio

SR = Torque Converter Stall Ratio (if applicable)

TCR = Transfer Case Ratio (if applicable)

Step 5 - Driveline Series Selection

To select a driveline series:

1. Use the torque determined from Steps 1, 2, and 3 with the overall low gear ratio (OLGR) from Step 4 to find the applicable series for each torque value.
2. Find the appropriate driveline series for SPL or Ten Series using the "Application Guidelines" on page 6 & 7.
3. Use the smallest series for the main driveline series, as determined from Steps 1, 2, and 3.

Note: The selected driveline series can not be more than one series smaller than the series selected from Step 1 (LGT).

Step 6 - Specifying the Interaxle Driveline (if applicable)

To specify the interaxle driveline, use:

1. 60% of the Driveline Series Selection torque from Step 5 and the OLGR from Step 4.
2. Find the appropriate interaxle driveline series for SPL or Ten Series using the "Application Guidelines" on page 6 & 7.

Note: High angle (45°) interaxle driveshafts are available in SPL-170 and 1710 Series only.

Calculating Maximum Driveshaft Torque (Export Applications)

Step 1 - Low Gear Torque Calculation

$$\text{LGT} = T \times \text{TLGR} \times \text{TE} \times \text{SR} \times \text{TCR} \times C$$

LGT = Maximum Driveshaft Low Gear Torque

T = Net Engine Torque or 95% of the Gross Engine Torque

TLGR = Transmission Low Gear Ratio (forward)

TE = Transmission Efficiency (automatic = 0.8; manual = 0.85)

SR = Torque Converter Stall Ratio (if applicable)

TCR = Transfer Case Ratio (if applicable)

C = Transfer Case Efficiency (if applicable, 0.95)

Step 2 - Overall Low Gear Ratio Calculation

$$\text{OLGR} = \text{TLGR} \times \text{SR} \times \text{TCR}$$

OLGR = Overall Low Gear Ratio

TLGR = Transmission Low Gear Ratio

SR = Torque Converter Stall Ratio (if applicable)

TCR = Transfer Case Ratio (if applicable)

Step 3 - Driveline Series Selection

To select a driveline series:

1. Use the torque determined from Step 1 with the overall low gear ratio (OLGR) from Step 2 to find the applicable series from the appropriate Driveline Sizing graph. See "Application Guidelines" for more information.

Step 4 - Specifying the Interaxle Driveline (if applicable)

To specify the interaxle driveline, use:

1. 60% of the Driveline Series Selection torque from Step 3 and the OLGR from Step 2.
2. Find the appropriate interaxle driveline series for SPL or Ten Series using the "Application Guidelines" on page 6 & 7.

Note: High angle (45°) interaxle driveshafts are available in SPL-170 and 1710 Series only.

Application Guidelines

10 Series Graph

Application Guidelines for Medium and Heavy-Duty Trucks

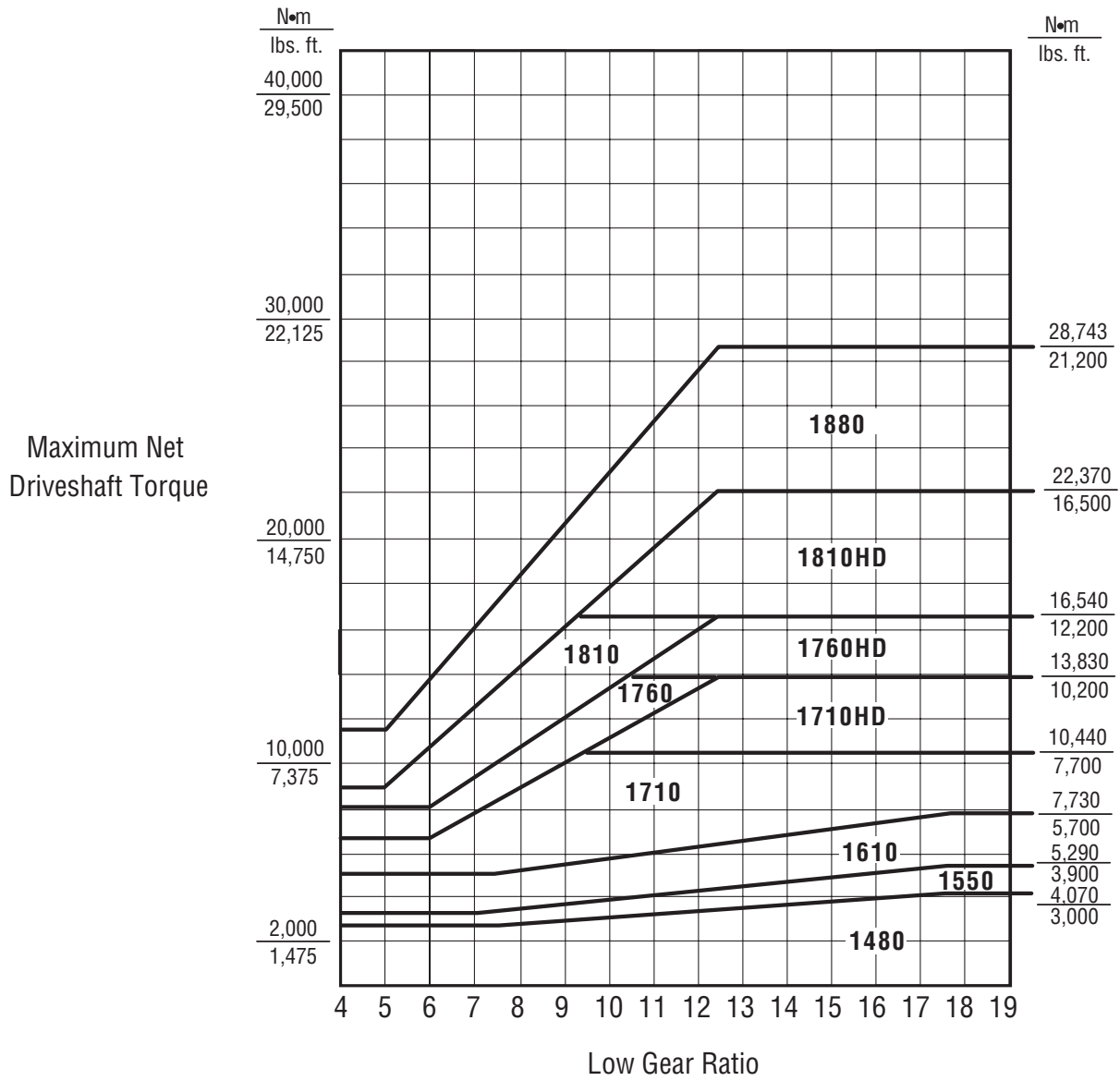

SPL Graph

Application Guidelines
for Medium and Heavy-Duty Trucks

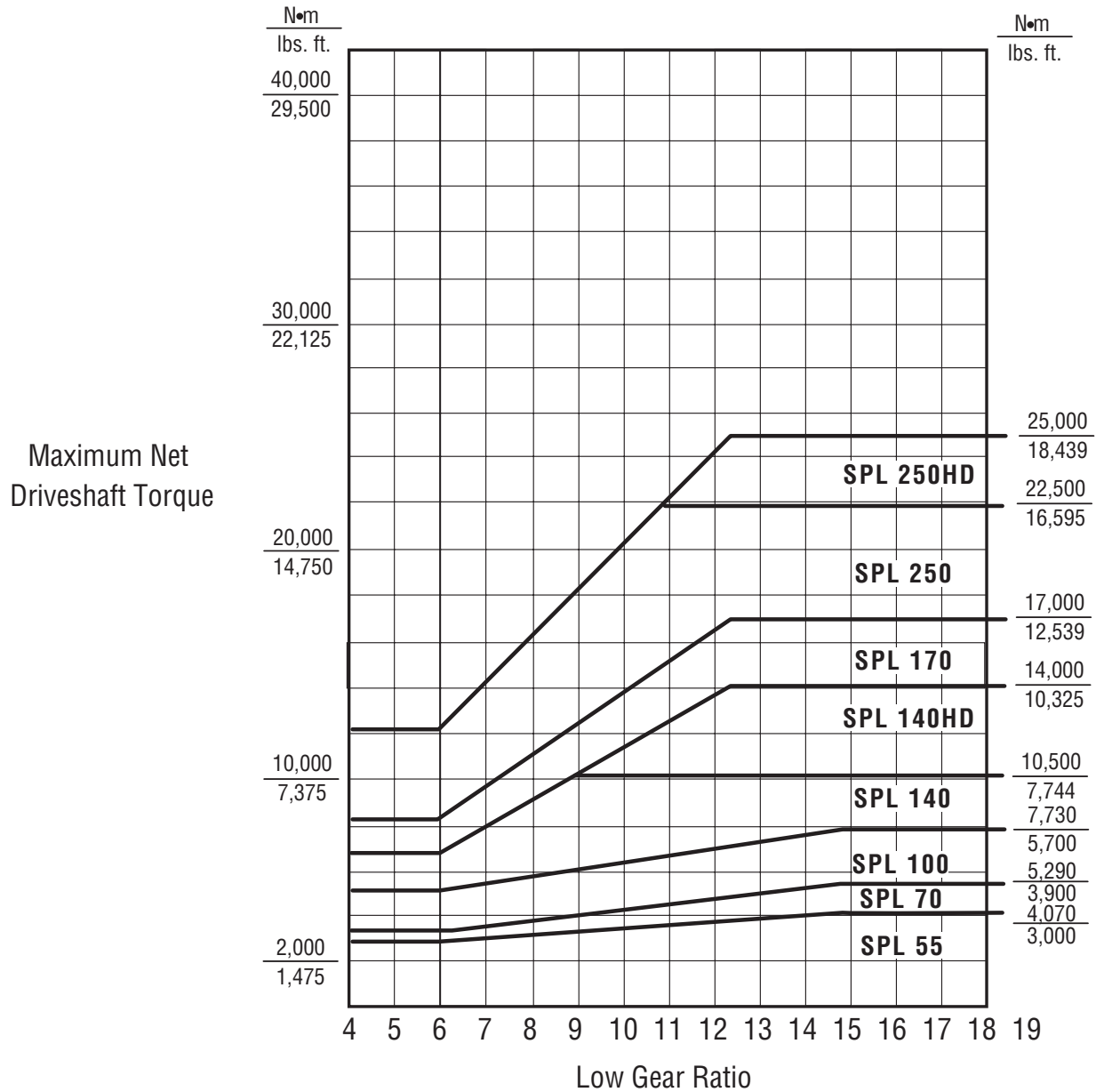

Application Guidelines

Critical Speed

Critical speed is defined as: The speed at which the rotational speed of the driveshaft coincides with the natural frequency of the shaft.

Standard Equation

$$CS = 30\pi \sqrt{\frac{E \times 386.4 (O^2 + I^2)}{P \times L^4 \times 16}}$$

CS = Critical Speed

E = Modulus of tubing material (psi)

O* = Outside Diameter of Tubing (in)

I* = Inside Diameter of Tubing (in)

P = Density of Tubing Material (lbs/in³)

L = Distance Between Journal Cross Centers (in)

* Refer to "Spicer Standard Tube Sizes" on page 19 for tube dimensions.

Material Properties

Material	Modulus	Density	E/P x 386.4
Steel	30.00 x 10 ⁶	0.2830	41.0 x 10 ⁹
Aluminum	10.30 x 10 ⁶	0.0980	39.4 x 10 ⁹

Simplified Equations

Steel:

$$CS = \frac{4.769 \times 10^6}{L^2} \sqrt{O^2 + I^2}$$

Aluminum:

$$CS = \frac{4.748 \times 10^6}{L^2} \sqrt{O^2 + I^2}$$

CS = Critical Speed

L = Distance Between Journal Cross Centers (in)

O = Outside Diameter of Tubing (in)

I = Inside Diameter of Tubing (in)

Note: The theoretical values and the simplified equation values are the same for the material constants provided.

Adjusted Critical Speed

$$ACS = TC \times CF \times SF$$

ACS = Adjusted Critical Speed

TC = Theoretical Critical

CF = Correction Factor

SF = Safety Factor

Suggested factors for Adjusted Critical Speed:

Safety Factor = 0.75

Correction Factor

Outboard Slip = 0.92

Inboard Slip = 0.75

Maximum Driveshaft Length

Refer to the TMC Recommended Practice RP610A Chart 3 for maximum driveshaft length vs. RPM guidelines.

The general length limitations are as follows:

Tube O.D.	Maximum Length *
3.0 in.	60 in.
3.5 in.	65 in.
4.0 in.	70 in.
4.2 in.	72 in.
4.3 in.	73 in.
4.5 in.	75 in.
5.0 in.	80 in.

* Installed length u-joint center to u-joint center.

Center Bearing Mounting

Spicer heavy duty center bearings must be mounted within 3° of perpendicular to the coupling shaft centerline as shown in Figure 1 below **OR** the center bearing assembly must not operate at a linear offset greater than $1/8"$ as shown in Figure 2.

Note: The Spicer "XC" center bearing may be mounted up to $\pm 10^\circ$ of perpendicular to the coupling shaft centerline as shown in the side view of Figure 1.

Figure 1

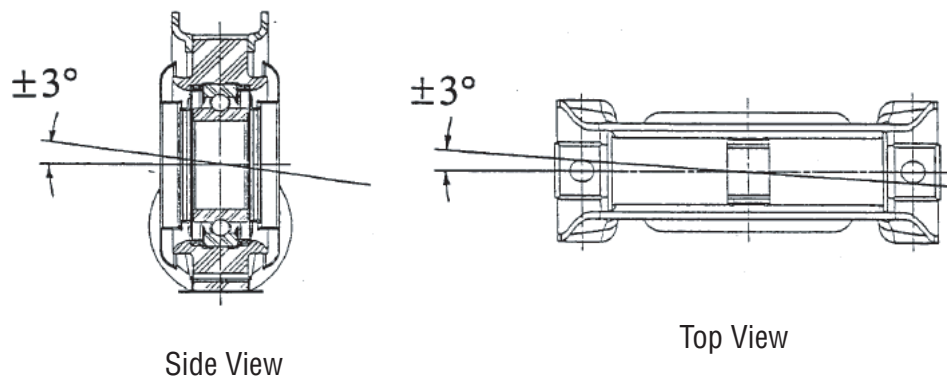
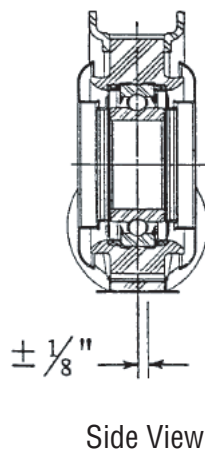

Figure 2



Driveline Analysis

Design Criteria

- Torsional Vibration
- Inertial Vibration
- Center Bearing Loading

Torsional and Inertial Excitation

Driveline Layout

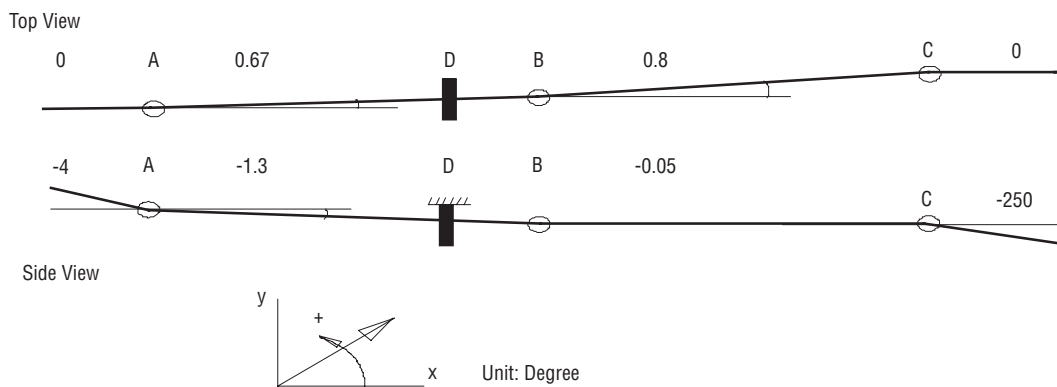

Calculate Joint Angles

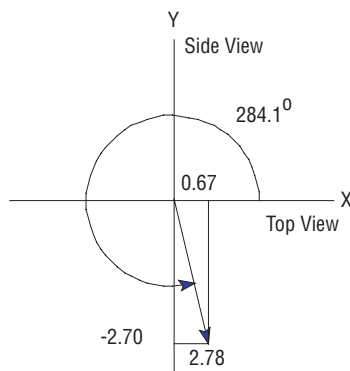

View from Rear of Driveline

To find the true joint angle of each joint, first find the top-view and side-view angles of each joint. The top-view angle of Joint A is equal to $0.67 - 0.00 = 0.67$ and the side-view joint angle of Joint A is equal to $(-4.0) - (-1.3) = -2.70$. By putting the top-view angle (0.67) to the X-axis and the side-view angle (-2.70) to the Y-axis, the true joint angle of Joint A is equal to $2.78 \angle 284.1$ degrees.

Note: The true joint angle is a vector: the 2.78 degrees is the magnitude and the 284.1 degree is the argument. The true joint angles of joints A, B, and C are shown in the following chart.

	Trans U-joint (A) degrees	U-joint (B) degrees	Axle U-joint (C) degrees
Joint Angle - Top View	0.67	0.13	-0.80
Joint Angle - Side View	-2.70	-1.25	2.45
True Joint Angle Θ	2.78	1.26	2.58
Plane of True Joint Angle ϕ	284.10	276.01	108.29

Calculate Torsional and Inertia Excitation

Calculate the torsional effect:

$$\Theta_{res} = \sqrt{(\Theta_1 | \phi_1)^2 + (\Theta_2 | (\phi_2 - 90^\circ - \delta_1))^2 + (\Theta_3 | (\phi_3 - \delta_2 - \delta_1))^2}$$

(1) When $\delta_1 = 0$ deg, $\delta_2 = 0$ deg.

$$\begin{aligned} &= \sqrt{(2.78 | 284.1^\circ)^2 + (1.26 | (276.01 - 90)^\circ)^2 + (2.58 | 108.29^\circ)^2} \\ &= \sqrt{(7.7284 | -151.8^\circ) + (1.5876 | 12.02^\circ) + (6.6564 | -143.42)} \\ &= \sqrt{(12.8667 | -145.4^\circ)} \\ &= 3.5870^\circ | -72.75^\circ \\ 3.3405 \times 10^{-6} (2368rpm)^2 (3.5870^\circ)^2 &= 241.0154 \frac{rad}{sec^2} \end{aligned}$$

(2) When $\delta_1 = 0$ deg, $\delta_2 = 90$ deg.

$$\begin{aligned} &= \sqrt{(2.78 | 284.1^\circ)^2 + (1.26 | (276.01 - 90 - 90)^\circ)^2 + (2.58 | (108.29 - 90)^\circ)^2} \\ &= \sqrt{(7.7284 | -151.8^\circ) + (1.5876 | 12.02^\circ) + (6.6564 | 36.58)} \\ &= \sqrt{(0.65124 | 82.32^\circ)} \\ &= 0.80699^\circ | 41.162^\circ \\ 3.3405 \times 10^{-6} (2368rpm)^2 (0.80699^\circ)^2 &= 12.1988 \frac{rad}{sec^2} \end{aligned}$$

(3) When $\delta_1 = 90$ deg, $\delta_2 = 90$ deg.

$$\begin{aligned} &= \sqrt{(2.78 | 284.1^\circ)^2 + (1.26 | (276.01 - 90 - 90)^\circ)^2 + (2.58 | (108.29 - 90 - 90)^\circ)^2} \\ &= \sqrt{(7.7284 | -151.8^\circ) + (1.5876 | -167.98^\circ) + (6.6564 | -143.42)} \\ &= \sqrt{(15.847236 | 149.89^\circ)} \\ &= 3.98085^\circ | -74.94^\circ \\ 3.3405 \times 10^{-6} (2368rpm)^2 (3.98085^\circ)^2 &= 296.84 \frac{rad}{sec^2} \end{aligned}$$

(4) When $\delta_1 = 90$ deg, $\delta_2 = 0$ deg.

$$\begin{aligned}
 &= \sqrt{(2.78_{-284.1^\circ})^2 + (1.26_{-(276.01-90-90)^\circ})^2 + (2.58_{-(108.29-90)^\circ})^2} \\
 &= \sqrt{(7.7284_{-151.8^\circ}) + (1.5876_{-167.98^\circ}) + (6.6564_{-36.58})} \\
 &= \sqrt{(3.018639_{-179.699^\circ})} \\
 &= 1.737423^\circ_{-89.84^\circ} \\
 3.3405 \times 10^{-6} (2368 \text{rpm})^2 (1.737423^\circ)^2 &= 56.54 \frac{\text{rad}}{\text{sec}^2}
 \end{aligned}$$

Calculate the inertia drive effects:

$$\Theta_D = \sqrt{2(\Theta_1 | \phi_1)^2 + (\Theta_2 | (\phi_2 - 90^\circ - \delta_1))^2}$$

(1) When $\delta_1 = 0$ deg, $\delta_2 = 0$ deg or $\delta_1 = 0$ deg, $\delta_2 = 90$ deg.

$$\begin{aligned}
 &= \sqrt{2(2.78_{-284.1^\circ})^2 + (1.26_{-(276.01-90)^\circ})^2} \\
 &= \sqrt{(15.4568_{-151.8^\circ}) + (1.5876_{-12.02^\circ})} \\
 &= \sqrt{(13.939105_{-149.98^\circ})} \\
 &= 3.733511^\circ_{-74.99^\circ} \\
 3.3405 \times 10^{-6} (2368 \text{rpm})^2 (3.733511^\circ)^2 &= 261.10 \frac{\text{rad}}{\text{sec}^2}
 \end{aligned}$$

(2) When $\delta_1 = 90$ deg, $\delta_2 = 90$ deg or $\delta_1 = 90$ deg, $\delta_2 = 0$ deg.

$$\begin{aligned}
 &= \sqrt{2(2.78_{-284.1^\circ})^2 + (1.26_{-(276.01-90-90)^\circ})^2} \\
 &= \sqrt{(15.4568_{-151.8^\circ}) + (1.5876_{-167.98^\circ})} \\
 &= \sqrt{(16.987278_{-153.29^\circ})} \\
 &= 4.12156^\circ_{-76.64^\circ} \\
 3.3405 \times 10^{-6} (2368 \text{rpm})^2 (4.12156^\circ)^2 &= 318.19 \frac{\text{rad}}{\text{sec}^2}
 \end{aligned}$$

Calculate the inertia coast effects:

$$\Theta_C = \sqrt{2(\Theta_3 | \phi_3)^2 + (\Theta_2 | (\phi_2 + 90^\circ + \delta_2))^2}$$

(1) When $\delta_1 = 0$ deg, $\delta_2 = 0$ deg or $\delta_1 = 90$ deg, $\delta_2 = 0$ deg.

$$\begin{aligned}
 &= \sqrt{2(2.58_{-108.29^\circ})^2 + (1.26_{-(276.01+90)^\circ})^2} \\
 &= \sqrt{(13.3128_{-143.42^\circ}) + (1.5876_{-12.02^\circ})} \\
 &= \sqrt{(11.887165_{-140.24^\circ})} \\
 &= 3.44777^\circ_{-70.11^\circ} \\
 3.3405 \times 10^{-6} (2368 \text{rpm})^2 (3.44777^\circ)^2 &= 222.66 \frac{\text{rad}}{\text{sec}^2}
 \end{aligned}$$

(2) When $\delta_1 = 0$ deg, $\delta_2 = 90$ deg or $\delta_1 = 90$ deg, $\delta_2 = 90$ deg.

$$\begin{aligned}
 &= \sqrt{2(2.58_{-108.29^\circ})^2 + (1.26_{-(276.01+90+90)^\circ})^2} \\
 &= \sqrt{(13.3128_{-143.42^\circ}) + (1.5876_{-167.98^\circ})} \\
 &= \sqrt{(14.77151_{-145.98^\circ})} \\
 &= 3.84337_{-72.99^\circ}
 \end{aligned}$$

$$3.3405 \times 10^{-6} (2368 \text{rpm})^2 (3.84337^\circ)^2 = 276.69 \frac{\text{rad}}{\text{sec}^2}$$

Note: The recommended torsional excitation level is 300 rad/sec² or less. The recommended inertia excitation level is 1000 rad/sec² or less.

Calculate the torque fluctuations:

The mass moment of inertia of the following items are approximately equal to:

	lbf-in-sec ²
Transmission	2.33
Axle	2.53
1760 Driveshaft	1.3

(1) The torque fluctuation at the axle end is:

$$\begin{aligned}
 T_{axle} &= T_{torsional,axle} + T_{inertia,drive} \\
 &= J_{axle \text{ torsional}} + J_{driveshaft \text{ drive}} \\
 &= (2.53)(241.01) + (1.3)(261.10) \\
 &= 949.18 \text{ in-lb} \\
 &= 79.1 \text{ ft-lb}
 \end{aligned}$$

(2) The torque fluctuation at the transmission end is:

$$\begin{aligned}
 T_{transmission} &= T_{torsional,transmission} + T_{inertia,coast} \\
 &= J_{transmission \text{ torsional}} + J_{driveshaft \text{ coast}} \\
 &= (2.33)(241.01) + (1.3)(222.66) \\
 &= 851.01 \text{ in-lb} \\
 &= 70.92 \text{ ft-lb}
 \end{aligned}$$

Center Bearing Loading

Calculate Static / Dynamic Center Bearing Load

Static

$$\begin{aligned}
 &= \frac{1}{2} \frac{T}{AB-DB} \left\{ \sin a^\circ _ (\phi_a + 90)^\circ + \left(\tan b^\circ - \frac{AB}{BC} \sin b^\circ \right) _ (\phi_b + 90)^\circ \right. \\
 &\quad \left. + \frac{AB}{BC} \tan c^\circ _ (\phi_c - 90)^\circ \right\} \\
 &= \frac{1}{2} \frac{12214 \times 12}{(40 - 6.2)} \left\{ \sin 2.78^\circ _ (284.1 + 90)^\circ \right. \\
 &\quad + \left(\tan 1.26^\circ - \frac{40}{44.34} \sin 1.26^\circ \right) _ (276.01 + 90)^\circ \\
 &\quad \left. + \frac{40}{44.34} \tan 2.58^\circ _ (108.29 - 90)^\circ \right\} \\
 &= 2168.1657 \{ (0.0485 _ 374.1^\circ) + (0.0022 _ 366.01^\circ) + (0.0406 _ 18.29^\circ) \} \\
 &= 2168.1657 (0.0912 _ 15.77^\circ) \\
 &= 197.7738 \text{ lbs } _ 15.77^\circ
 \end{aligned}$$

Dynamic

$$\begin{aligned}
 &= \frac{1}{2} \frac{T}{AB-DB} \left\{ \sin a^\circ _ (90 - \phi_a)^\circ + \left(\tan b^\circ + \frac{AB}{BC} \sin b^\circ \right) _ (90 - \phi_b + 2\delta_1)^\circ \right. \\
 &\quad \left. + \frac{AB}{BC} \tan c^\circ _ (90 - \phi_c + 2\delta_1 + 2\delta_2)^\circ \right\}
 \end{aligned}$$

(1) When $\delta_1 = 0$ deg, $\delta_2 = 0$ deg.

$$\begin{aligned}
 &= \frac{1}{2} \frac{12214 \times 12}{(40 - 6.2)} \left\{ \sin 2.78^\circ _ (90 - 284.1)^\circ \right. \\
 &\quad + \left(\tan 1.26^\circ + \frac{40}{44.34} \sin 1.26^\circ \right) _ (90 - 276.01)^\circ \\
 &\quad \left. + \frac{40}{44.34} \tan 2.58^\circ _ (90 - 108.29)^\circ \right\} \\
 &= 2168.1657 \{ (0.0485 _ -194.1^\circ) + (0.0418 _ -186.01^\circ) + (0.0406 _ -18.29^\circ) \} \\
 &= 2168.1657 (0.0502 _ 176.^\circ) \\
 &= 108.7635 \text{ lbs } _ 176.^\circ
 \end{aligned}$$

(2) When $\delta_1 = 0$ deg, $\delta_2 = 90$ deg.

$$\begin{aligned}
 &= \frac{1}{2} \frac{12214 \times 12}{(40.-6.2)} \{ \sin 2.78^\circ _ (90-284.1)^\circ \\
 &+ (\tan 1.26^\circ + \frac{40.}{44.34} \sin 1.26^\circ) _ (90-276.01)^\circ \\
 &+ \frac{40.}{44.34} \tan 2.58^\circ _ (90-108.29+2 \times 90)^\circ \} \\
 &= 2168.1657 \{ (0.0485 _ -194.1^\circ) + (0.0418 _ -186.01^\circ) + (0.0406 _ -161.71^\circ) \} \\
 &= 2168.1657 (0.1305 _ -167.18^\circ) \\
 &= 282.9240 \text{ lbs } _ -167.18^\circ
 \end{aligned}$$

(3) When $\delta_1 = 90$ deg, $\delta_2 = 90$ deg.

$$\begin{aligned}
 &= \frac{1}{2} \frac{12214 \times 12}{(40.-6.2)} \{ \sin 2.78^\circ _ (90-284.1)^\circ \\
 &+ (\tan 1.26^\circ + \frac{40.}{44.34} \sin 1.26^\circ) _ (90-276.01+2 \times 90)^\circ \\
 &+ \frac{40.}{44.34} \tan 2.58^\circ _ (90-108.29)^\circ \} \\
 &= 2168.1657 \{ (0.0485 _ -194.1^\circ) + (0.0418 _ -6.01^\circ) + (0.0406 _ -18.29^\circ) \} \\
 &= 2168.1657 (0.0336 _ -9.11^\circ) \\
 &= 72.8115 \text{ lbs } _ -9.11^\circ
 \end{aligned}$$

(4) When $\delta_1 = 90$ deg, $\delta_2 = 0$ deg.

$$\begin{aligned}
 &= \frac{1}{2} \frac{12214 \times 12}{(40.-6.2)} \{ \sin 2.78^\circ _ (90-284.1)^\circ \\
 &+ (\tan 1.26^\circ + \frac{40.}{44.34} \sin 1.26^\circ) _ (90-276.01+2 \times 90)^\circ \\
 &+ \frac{40.}{44.34} \tan 2.58^\circ _ (90-108.29+2 \times 90)^\circ \} \\
 &= 2168.1657 \{ (0.0485 _ -194.1^\circ) + (0.0418 _ -6.01^\circ) + (0.0406 _ -161.71^\circ) \} \\
 &= 2168.1657 (0.0484 _ -155.36^\circ) \\
 &= 105.03326 \text{ lbs } _ -155.36^\circ
 \end{aligned}$$

Center Bearing Loads

Design	Static Load	Dynamic Load
Solid Rubber	500 lbs.	500 lbs.
Semi-Slotted Rubber	250 lbs.	250 lbs.
Slotted Rubber	100 lbs.	100 lbs.

Application Form



Heavy / Medium-Duty Applications

Company: _____ Contact: _____

Email: _____ Date: _____

Phone: _____ Fax: _____

Vocation: _____ Vehicle Make: _____ Vehicle Model: _____

Weight - Empty: _____ GVW Total: _____

GVW (Front): _____ GVW (Rear): _____ GCW: _____

Tires - Size: _____ Make: _____ Rolling Radius: _____

Engine - Make: _____ Model: _____ Displacement: _____

Net Torque: _____ At Speed: _____ Net H.P.: _____ At Speed: _____

Gross Torque: _____ At Speed: _____ Gross H.P.: _____ At Speed: _____

Maximum Operating Speed (including engine over speed): _____

Trans - Make: _____ Model: _____

Ratios - Forward (including overdrive): _____ Reverse: _____

Torque Converter - Make: _____ Model: _____ Stall Ratio: _____

Auxiliary - Make: _____ Model: _____ Ratios: _____

Transfer Case - Make: _____ Model: _____ Ratios: _____

Torque Split Ratio - Front: _____ Rear: _____

Axle Make - Front: _____ Model: _____ Ratios: _____

Make - Front: _____ Model: _____ Ratios: _____

B₁₀ Life Expectancy: _____

Vehicle Duty Cycle: _____

Description of Vehicle Function: _____

Signed: _____

Title: _____

Spicer Engineer: _____ Phone: _____

Email: _____ Fax: _____

Application Form





Heavy / Medium-Duty Applications

APPLICATION PROPOSAL

Vehicle Position	Series	Dana Part Number
Transmission to Rear Axle		
Transmission to Auxiliary		
Auxiliary to Rear Axle		
Transmission to Mid Bearing		
Mid Bearing to Rear Axle		
Interaxle		
Wheel Drive		

Vehicle Application Sketch	
Plan View	
Side View	

Proposed By: _____

Signed: _____

Title: _____



Spicer Standard Tube Sizes

Series	Tube Size (in)	Dana Part Number	Torque Rating (lbs. ft.)	Tube JAEL (lbs. ft.)
1610	4.00 x .134	32-30-52	5,700	8,600
1710	4.00 x .134	32-30-52	7,700	8,600
1710 HD	4.09 x .180	32-30-72	10,200	13,925
1760	4.00 x .134	32-30-92	10,200	10,435
1760 HD	4.09 x .180	32-30-72	12,200	13,925
1810	4.50 x .134	36-30-62	12,200	13,065
1810 HD	4.59 x .180	36-30-102	16,500	17,935
SPL 90	4.00 x .095	32-30-12	4,900	6,300
SPL 100	4.00 x .095	32-30-12	5,700	6,300
SPL 140	4.21 x .138	100-30-3	7,744	11,010
SPL 140 HD	4.33 x .197	100-30-5	10,325	16,519
SPL 170	4.96 x .118	120-30-3	12,539	13,185
SPL 170 HD	5.06 x .167	120-30-4	12,539	19,617
SPL 170 I/A	4.72 x .197	110-30-5	12,539	19,875
SPL 250	5.06 x .167	120-30-4	16,595	19,617
SPL 250 HD	5.12 x .197	120-30-5	18,439	23,555

Joint Life vs. Joint Angle

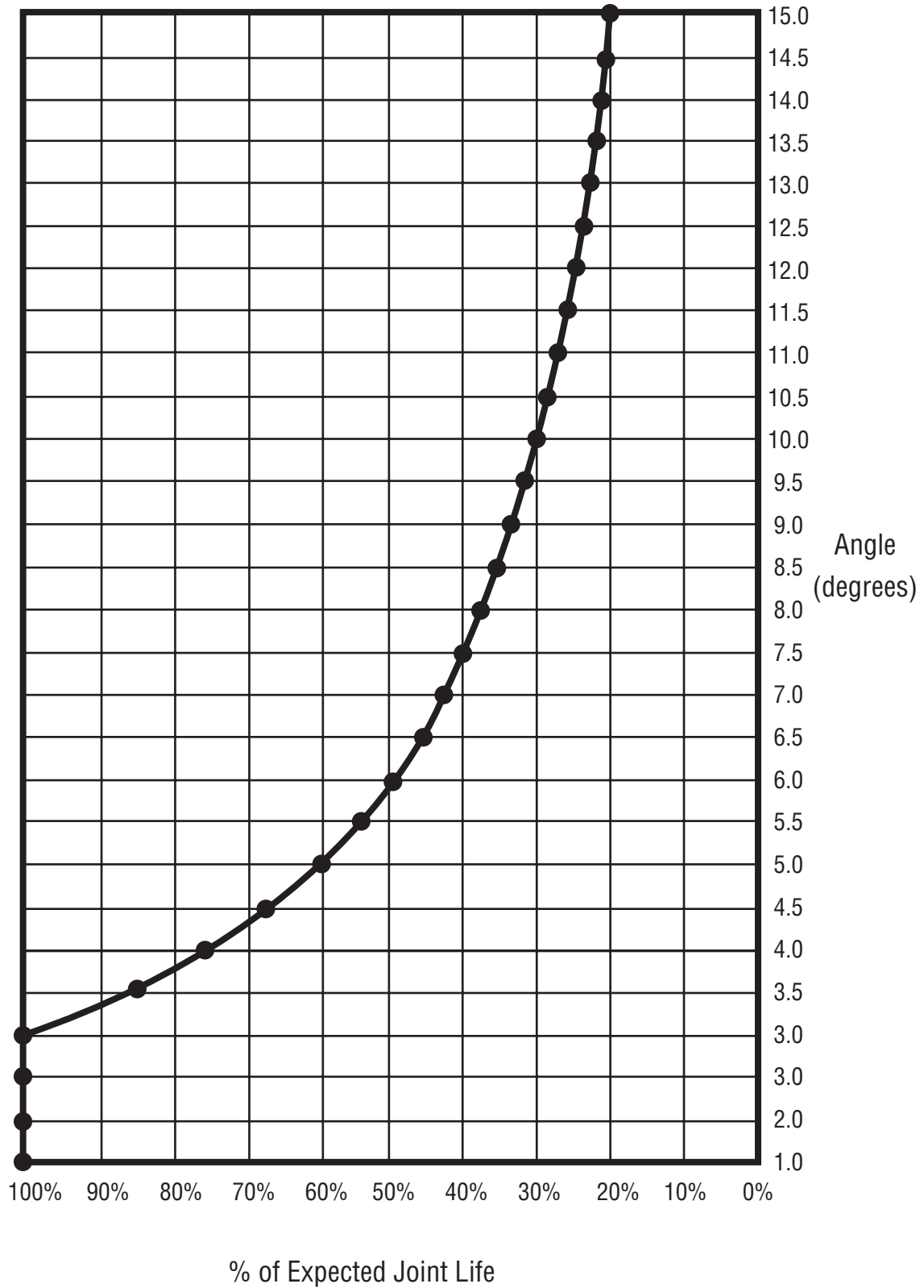

Charts

Snap Ring Cross Holes

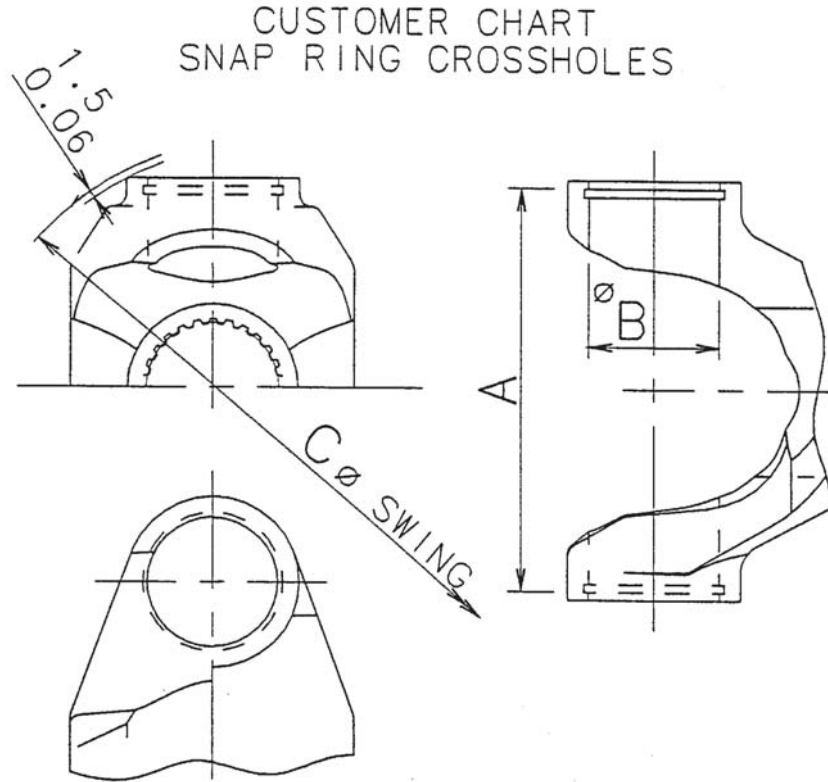

Type	Series	A (mm / in)	B (mm / in)	C* (mm / in)
Snap Ring Construction	1210	65.0 / 2.56	26.9 / 1.06	79.2 / 3.12
	1280 / 1310	84.8 / 3.34	26.9 / 1.06	96.8 / 3.81
	1330	95.0 / 3.74	26.9 / 1.06	106.4 / 4.19
	1350	95.0 / 3.74	30.2 / 1.19	108.0 / 4.25
	1410	109.2 / 4.30	30.2 / 1.19	124.0 / 4.88
	1480 / SPL 55	109.2 / 4.30	34.8 / 1.37	124.0 / 4.88
	1550 / SPL 70	129.0 / 5.08	34.8 / 1.37	144.5 / 5.69
	SPL 90 / SPL 100	130.6 / 5.14	41.1 / 1.62	149.4 / 5.88
	1650	146.8 / 5.78	41.1 / 1.62	165.1 / 6.50

* Swing diameter clears yoke by 1.5 mm / 0.06 in.

Half Round Cross Holes

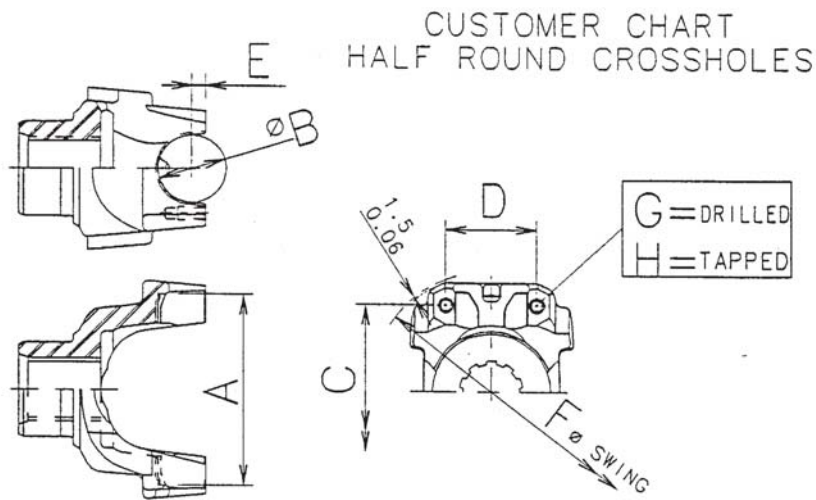

Type	Series	A (mm / in)	B (mm / in)	C (mm / in)	D (mm / in)	E (mm / in)	F* (mm / in)	G (mm / in)	H
U-bolt Design	1210	62.0 / 2.44	26.9 / 1.06	56.4 / 2.22	35.8 / 1.41	0.8 / 0.03	87.4 / 3.44	8.4 / 0.33	-
	1280/1310	81.8 / 3.22	26.9 / 1.06	73.9 / 2.91	35.8 / 1.41	0.8 / 0.03	101.6 / 4.00	8.4 / 0.33	-
	1330	91.9 / 3.62	26.9 / 1.06	84.1 / 3.31	35.8 / 1.41	0.8 / 0.03	115.8 / 4.56	8.4 / 0.33	-
	1350	91.9 / 3.62	30.2 / 1.19	81.0 / 3.19	42.2 / 1.66	0.8 / 0.03	115.8 / 4.56	9.9 / 0.39	-
	1410	106.4 / 4.19	30.2 / 1.19	95.2 / 3.75	42.2 / 1.66	0.8 / 0.03	125.5 / 4.94	9.9 / 0.39	-
	1480	106.4 / 4.19	35.1 / 1.38	93.7 / 3.69	48.5 / 1.91	0.8 / 0.03	134.9 / 5.31	11.7 / 0.46	-
	1550	126.2 / 4.97	35.1 / 1.38	113.5 / 4.47	48.5 / 1.91	0.8 / 0.03	152.4 / 6.00	11.7 / 0.46	-
Bearing Strap Tapped Hole	1210	62.0 / 2.44	26.9 / 1.06	53.8 / 2.12	40.1 / 1.58	0.8 / 0.03	87.4 / 3.44	-	0.25 - 28
	1280/1310	81.8 / 3.22	26.9 / 1.06	73.9 / 2.91	40.1 / 1.58	0.8 / 0.03	101.6 / 4.00	-	0.25 - 28
	1330	91.9 / 3.62	26.9 / 1.06	84.1 / 3.31	40.1 / 1.58	0.8 / 0.03	115.8 / 4.56	-	0.25 - 28
	1350	91.9 / 3.62	30.2 / 1.19	81.0 / 3.19	45.7 / 1.80	0.8 / 0.03	115.8 / 4.56	-	0.312 - 24
	1410	106.4 / 4.19	30.2 / 1.19	95.2 / 3.75	45.7 / 1.80	0.8 / 0.03	125.5 / 4.94	-	0.312 - 24
	1480	106.4 / 4.19	35.1 / 1.38	93.7 / 3.69	53.8 / 2.12	0.8 / 0.03	134.9 / 5.31	-	0.375 - 24
	1550	126.2 / 4.97	35.1 / 1.38	113.5 / 4.47	53.8 / 2.12	0.8 / 0.03	152.4 / 6.00	-	0.375 - 24
	1610	134.9 / 5.31	47.8 / 1.88	122.2 / 4.81	63.5 / 2.50	9.7 / 0.38	171.4 / 6.75	-	0.375 - 24
	1710	157.2 / 6.19	49.3 / 1.94	142.0 / 5.59	71.4 / 2.81	7.9 / 0.31	190.5 / 7.50	-	0.50 - 20
	1760	180.1 / 7.09	49.3 / 1.94	165.1 / 6.50	71.4 / 2.81	7.9 / 0.31	212.9 / 8.38	-	0.50 - 20
	1810	194.1 / 7.64	49.3 / 1.94	179.1 / 7.05	71.4 / 2.81	7.9 / 0.31	228.6 / 9.00	-	0.50 - 20
Bearing Strap Thru-Hole	1410	106.4 / 4.19	30.2 / 1.19	95.2 / 3.75	45.7 / 1.80	0.8 / 0.03	125.5 / 4.94	8.4 / 0.33	-
	1480	106.4 / 4.19	35.1 / 1.38	93.7 / 3.69	53.8 / 2.12	0.8 / 0.03	134.9 / 5.31	9.9 / 0.39	-
	1550	126.2 / 4.97	35.1 / 1.38	113.5 / 4.47	53.8 / 2.12	0.8 / 0.03	152.4 / 6.00	9.9 / 0.39	-

* Swing diameter clears yoke by 1.5 mm / 0.06 in.

SPL Full Round Cross Holes

CUSTOMER CHART SPL FULL ROUND CROSSHOLES

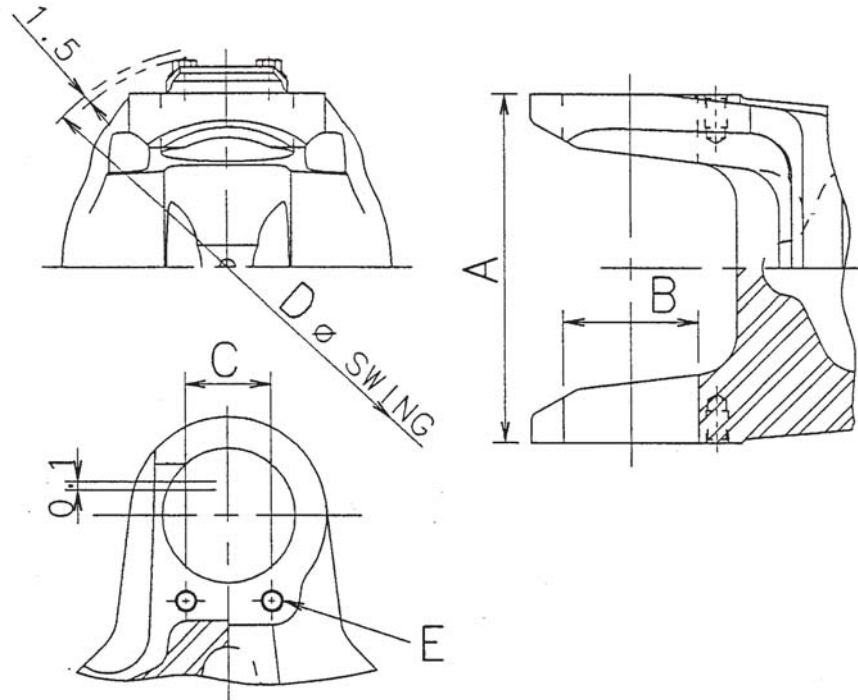

Type	Series	A (mm)	B (mm)	C (mm)	D * (mm)	E (mm)
SPL Full Round	SPL 140	128	49	32	160	M8 x 1.00
	SPL 170	153	55	32	185	M8 x 1.00
	SPL 250	152	60	32	184	M8 x 1.00

* Swing diameter clears yoke by 1.5 mm.

SPL Half Round Cross Holes

CUSTOMER CHART SPL
HALF ROUND CROSSHOLES

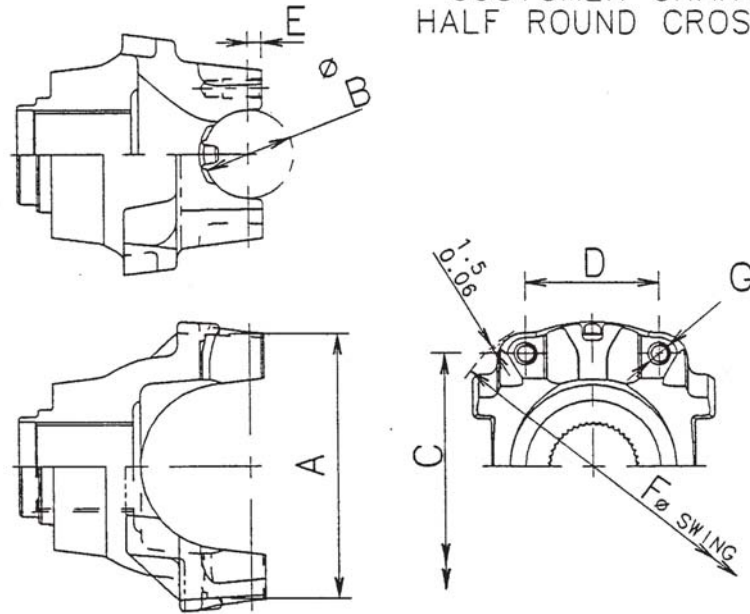

Type	Series	A (mm)	B (mm)	C (mm)	D (mm)	E (mm)	F * (mm)	G (mm)
Bearing	SPL 55	106.4	35.1	93.7	53.8	0.8	134.9	0.375 x 24 UNF
	SPL 70	126.2	35.1	113.5	53.8	0.8	152.4	0.375 x 24 UNF
Strap	SPL 90 / 100	126	41	115	59	6	154	0.375 x 24 UNF
Tapped	SPL 140	139	49	113	76	8	174	12 x 1.25
Hole	SPL 170	164	55	140	82	8	193	12 x 1.25
	SPL 250	163	60	135	88	10	193	12 x 1.25

BP Cross Holes

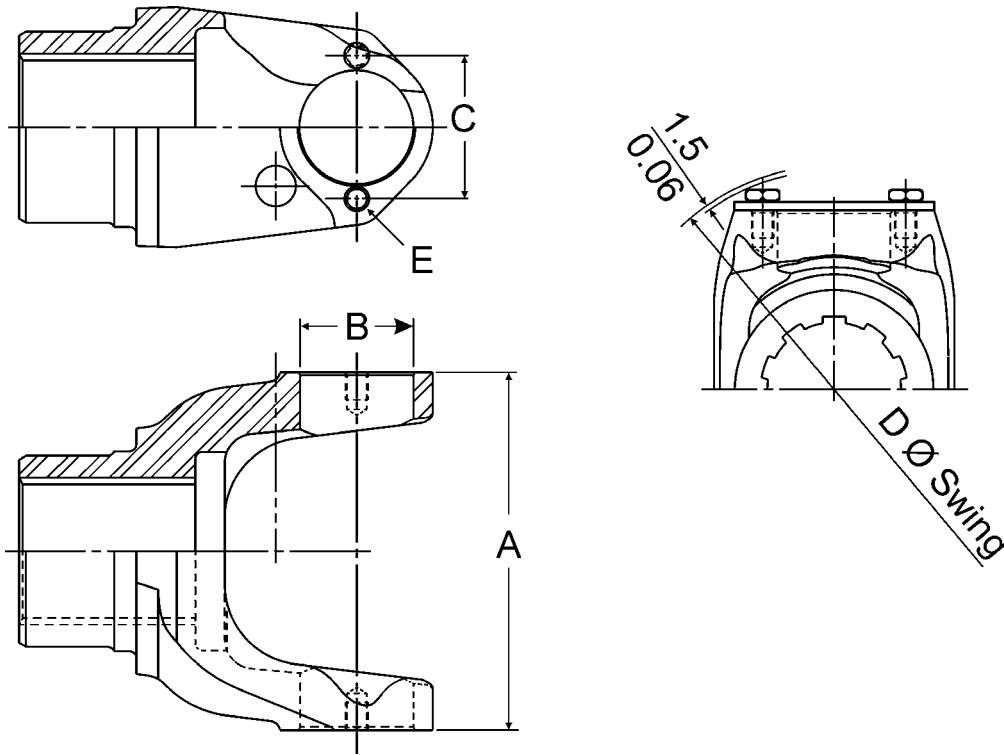

Type	Series	A (mm)	B (mm)	C (mm)	D* (mm)	E (mm)
Bearing	1610	134.9/5.31	47.8/1.88	58.7/2.31	180.8/7.12	0.312-24
Plate	1710	154.7/6.09	49.3/1.94	62.0/2.44	200.2/7.88	0.375-24
	1760	177.8/7.00	49.3/1.94	62.0/2.44	220.5/8.68	0.375-24
Full	1810	191.8/7.55	49.3/1.94	62.0/2.44	235.0/9.25	0.375-24
Round	1880	205.5/8.09	55.6/2.19	71.4/2.81	250.9/9.88	0.438-20

*Swing Diameter Clears Yoke by 1.5/0.06 mm/in.

Joint Kit Attaching Hardware and Torque Specifications

U-bolts

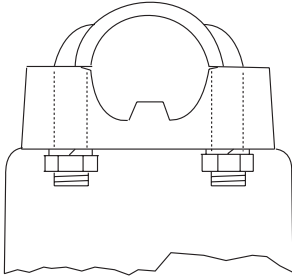

Series	Spicer Kit No	Assemblies	Recommended Nut Torque
1210	5-443X	-	-
1310, SPL22	5-153X, 5-785X, SPL22-1X	2-94-28X	14-17 lbs. ft.
1330, SPL25	5-213X, 5-790X, SPL25-1X	2-94-28X	14-17 lbs. ft.
1350, SPL30	5-178X, 5-799X, SPL30-1X	3-94-18X	20-24 lbs. ft.
1410, SPL36	5-160X, 5-801X, SPL36-1X	3-94-18X	20-24 lbs. ft.
1480, SPL55	5-188X, 5-803X, SPL55X	3-94-28X	32-37 lbs. ft.
1550, SPL70	5-155X, 5-808X, SPL70X	3-94-28X	32-37 lbs. ft.
3R	5-3147X, 5-795X, SPL25-6X	2-94-58X	17-24 lbs. ft.

Bearing Strap



WARNING: Bearing strap retaining bolts should not be reused.

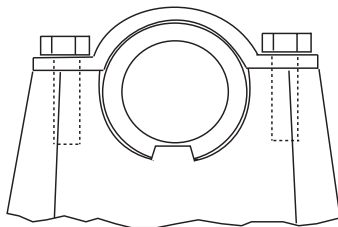

Series	Spicer Kit No	Assemblies	Recommended Bolt Torque
SPL90	SPL90X	90-70-28X	45-60 lbs. ft.
SPL100	SPL100-1X	90-70-28X	45-60 lbs. ft.
1210	5-443X	2-70-18X	13-18 lbs. ft.
1310, SPL22	5-153X, 5-785X, SPL22-1X	2-70-18X	13-18 lbs. ft.
1330, SPL25	5-213X, 5-790X, SPL25-1X	2-70-18X	13-18 lbs. ft.
1350, SPL30	5-178X, 5-799X, SPL30-1X	3-70-28X	30-35 lbs. ft.
1410, SPL36	5-160X, 5-801X, SPL36-1X	3-70-28X	30-35 lbs. ft.
1480, SPL55	5-188X, 5-803X, SPL55X	3-70-28X	30-35 lbs. ft.
1550, SPL70	5-155X, 5-808X, SPL70X	3-70-28X	30-35 lbs. ft.
1610	5-674X	5-70-28X	45-60 lbs. ft.
1710	5-675X	6.5-70-18X	115-135 lbs. ft.
1760	5-677X	6.5-70-18X	115-135 lbs. ft.
1810	5-676X	6.5-70-18X	115-135 lbs. ft.
3R	5-3147X, 5-795X, SPL25-6X	2-70-48X	30-35 lbs. ft.
7260	5-1306X, 5-789X, SPL22-8X	2-70-38X	13-18 lbs. ft.

Cap and Bolts

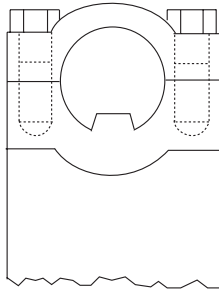

(*) Discontinued

Series	Spicer Kit No	Assemblies	Recommended Bolt Torque
1650	5-165X	5-70-18X	77-103 lbs. ft.
1850	5-185X	8-70-18X (*)	110-147 lbs. ft.
2050	5-340X	9-70-28X (*)	744-844 lbs. ft.

Bearing Plate



WARNING: Self locking bolts should not be reused.

Serrated Bolts with Lock Patch / No Lock Strap (Models after Spring 1994)

Series	Bolt Part No	Thread Size	Recommended Bolt Torque
1610	5-73-709	.312-24	26-35 lbs. ft.
1710	6-73-209	.375-24	38-48 lbs. ft.
1760	6-73-209	.375-24	38-48 lbs. ft.
1810	6-73-209	.375-24	38-48 lbs. ft.
1880	7-73-315	.438-20	60-70 lbs. ft.

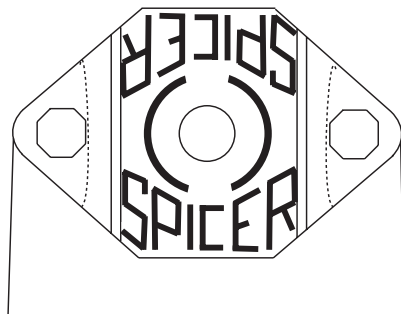

Bolt with Lock Strap (Pre-Spring 1994 Models)

Series	Bolt Part No	Thread Size	Recommended Bolt Torque
1610	5-73-109	.312-24	26-35 lbs. ft.
1710	6-73-109	.375-24	38-48 lbs. ft.
1760	6-73-109	.375-24	38-48 lbs. ft.
1810	6-73-109	.375-24	38-48 lbs. ft.
1880	7-73-115 (*)	.438-20	60-70 lbs. ft.

Quick Disconnect (Half Round)

Series	Bolt Part No	Thread Size	Recommended Bolt Torque
SPL90	6-73-412	.375-24	45-60 lbs. ft.
1610	6-73-412	.375-24	45-60 lbs. ft.
1710	8-73-316	.500-20	115-135 lbs. ft.
1760	8-73-316	.500-20	115-135 lbs. ft.
1810	8-73-316	.500-20	115-135 lbs. ft.

Bearing Retainer

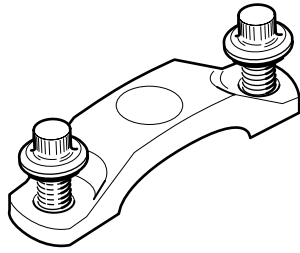

Series	Spicer Kit No	Retainer Kit No	Bolt Part No	Recommended Bolt Torque
SPL140	SPL140X	140-70-18X	5007417	115-135 lbs. ft.
SPL170	SPL170X	170-70-18X	5007417	115-135 lbs. ft.
SPL250	SPL250X	250-70-18X	5007417	115-135 lbs. ft.

Spring Tab

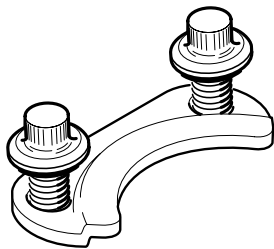

Series	Spicer Kit No	Spring Tab Kit No	Bolt Part No	Recommended Bolt Torque
SPL140	SPL140X	211941X	8-73-114M	25-30 lbs. ft.
SPL170	SPL170X	211941X	8-73-114M	25-30 lbs. ft.
SPL250	SPL250X	211941X	8-73-114M	25-30 lbs. ft.

Copyright Eaton and Dana Corporation, 2007. EATON AND DANA CORPORATION hereby grants its customers, vendors, or distributors permission to freely copy, reproduce and/or distribute this document in printed format. It may be copied only in its entirety without any changes or modifications. THIS INFORMATION IS NOT INTENDED FOR SALE OR RESALE, AND THIS NOTICE MUST REMAIN ON ALL COPIES.



National Institute for
**AUTOMOTIVE
SERVICE
EXCELLENCE**

Roadranger®



For specifying or service assistance, call 1-800-826-HELP (4357) 24 hours a day, 7 days a week (Mexico: 001-800-826-4357), for more time on the road. Or visit our web site at www.roadranger.com.

Roadranger: Eaton, Dana and other trusted partners providing the best products and services in the industry, ensuring more time on the road.